

Hardware Installation Guide

Revision 1.0

Preface

Copyright 2003

All rights Reserved- Printed in Taiwan

Notice

We make no warranties with respect to this documentation either express or implied and provide it "as it". This includes but is not limited to any implied warranties of merchantability and fitness for a particular purpose. The information in this document is subject to change without notice. We assume no responsibility for any errors that may appear in this document.

The manufacturer shall not be liable for any damage, or for the loss of information resulting from the performance or use of the information contained herein

Trademarks

Product names used herein are for identification purposes only and may be the trademarks of their respective companies. All trademarks or registered trademarks are properties of their respective owners.

Regulatory information

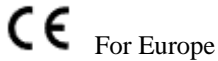

This drive is in conformity with the EMC directive.



This equipment has been tested and found to comply with the limits for a Class A digital device, pursuant to part 15 of the FCC Rules.

Those limits are designed to provide reasonable protection against harmful interference in a residential installation. This equipment generates, uses and can radiate radio frequency energy and, if not installed and used in accordance with the instructions, may cause harmful interference to radio communications. However, there is no guarantee that interference will not occur in a particular installation. If this equipment does cause harmful interference to radio or television reception, which can be determined by turning the equipment off and on, the user is encouraged to try to correct the interference by one or more of the following measures:

Reorient or relocate the receiving antennas.

Increase the separation between the equipment and receiver.

Connect the equipment into an outlet on a circlet different from that to which the receiver is connected.

Consult the dealer or an experienced radio/TV technician for help.

Warning:

A shielded-type power cord is required in order to meet FCC emission limits and also to prevent interference to the nearby radio and television reception. It is essential that only the supplied power cord be used.

Use only shielded cables to connect I/O devices to this equipment.

You are cautioned that changes or modifications not expressly approved by the party responsible for compliance could void your authority to operate the equipment.

General Safety Guidelines



DO NOT place the RAID SYSTEM on uneven or unstable work surfaces. Seek servicing if the casing has been damaged.

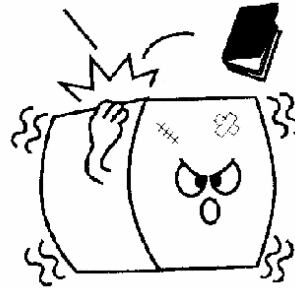

DO NOT place or drop objects on top of the RAID SYSTEM and do not shove any foreign object into it.



DO NOT expose RAID SYSTEM to liquids, rain, or moisture.

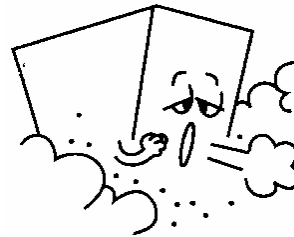

DO NOT expose RAID SYSTEM to dirty or dusty environments.



DO NOT expose RAID SYSTEM to magnetic field.

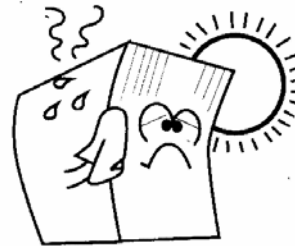

DO NOT expose RAID SYSTEM to extreme temperatures (below 5°C or above 45°C) or to direct sunlight.

About your User's Guide

Welcome to your Hardware Installation Guide. This manual covers everything you need to know in

Hardware Installation Guide

learning how to install your RAID system. This manual also assumes that you know the basic concepts of RAID technology. For the detail about how to configure your RAID system, please refer to the RAID system Software Operation manual.

Guide to conventions

Important information that users should be aware of is indicated with the following icons:

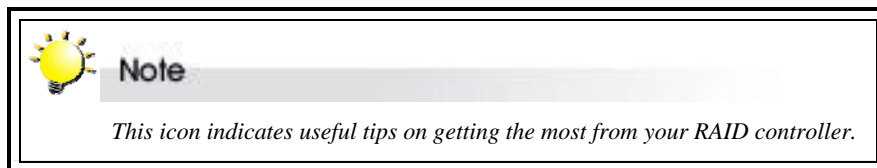
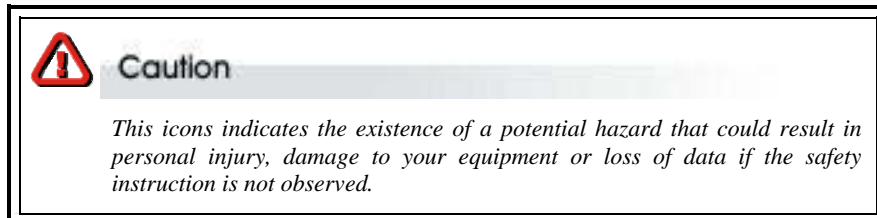

Important terms, commands and programs are put in Boldface font.

Screen text is given in screen font.

Table of Contents

PREFACE	1
COPYRIGHT 2003	1
NOTICE	1
TRADEMARKS	1
REGULATORY INFORMATION	2
GENERAL SAFETY GUIDELINES	3
ABOUT YOUR USER’S GUIDE	3
GUIDE TO CONVENTIONS	4
TABLE OF CONTENTS	5
CHAPTER 1	7
INTRODUCTION.....	7
FEATURE HIGHLIGHT.....	7
BEFORE YOU BEGIN	8
<i>Unpacking & Checking The Equipment</i>	<i>8</i>
<i>What else you need.....</i>	<i>9</i>
IDENTIFYING PARTS OF THE RAID SYSTEM	10
<i>Front View.....</i>	<i>10</i>
<i>Rear View</i>	<i>12</i>
SPACE REQUIREMENT	15
SYSTEM CONNECTION	15
<i>Cable</i>	<i>15</i>
<i>RAID system</i>	<i>15</i>
<i>Device.....</i>	<i>15</i>
<i>Purpose.....</i>	<i>15</i>
INSTALL HARD DISKS	16
CHAPTER 2	18
HARDWARE INSTALLATION	18
REPLACE THE CONTROLLER	18

Hardware Installation Guide

REPLACING / UPGRADING DDR SDRAM.....	21
<i>DDR SDRAM DIMM specifications:</i>	21
<i>Installing memory module</i>	22
HOT SWAPPING TO REPLACE THE FAN MODULE	23
HOT SWAPPING TO REPLACE THE POWER MODULE	25
TURNING ON FOR THE FIRST TIME.....	26
TURNING OFF.....	26
RESTARTING.....	26
<i>APPENDIX A</i>	27
TROUBLE SHOOTING	27
<i>APPENDIX B</i>	31
CONNECTORS	31
<i>APPENDIX C</i>	33
SPECIFICATIONS	33

Chapter 1

Introduction

This chapter introduces the features and capabilities of RAID SYSTEM.

You will find:

- ⇒ **A full introduction to your RAID SYSTEM**
- ⇒ **Details of key features and supplied accessories**
- ⇒ **A checklist of package contents**
- ⇒ **A checklist of what else you need to start installation**

Feature Highlight

The RAID SYSTEM is designed to meet today's high volume, performance storage requirements from rapidly changing business environment. It provides a maximum data protection and exceptional performance in a storage subsystem. Target usage ranges are set from small business to departmental and corporate server needs. The RAID SYSTEM is designed for easy integration, smooth data expansion and server migration.

The RAID SYSTEM supports the following features:

- * Host System independent
- * Operating System independent
- * High performance processor
- * Superior Array Management Firmware
- * Advanced PCI-X bus architecture
- * Flexible cache size of up to 2GB (DDR333 SDRAM)
- * Support for RAID Levels 0, 1,0+1, 3, 5,30,50,6,6+, NRAID & JBOD
- * Dual Ultra-320 SCSI Host Interconnect support by SCSI to SATAII
- * Dual Loop of 2Gb/sec Fibre Channel support by Fibre to SATA II
- * Redundant and Hot Swappable Fan, Power and Drives.
- * Hot Swap, Hot Spare and Automatic Drive Rebuild Support
- * Programmable Page and FAX event notification

- * Remote monitoring through network port
- * Load-sharing hot swappable redundant power system with PFC function .

Before you begin

Unpacking & Checking The Equipment

Before unpacking the RAID SYSTEM, prepare a clean, stable surface to put on the contents of your RAID SYSTEM shipping container. Altogether, you should find the following items in the package:

SCSI to ATA RAID System

- RAID System x1
- RAID system Hardware Installation Guide (CD media)
- RAID system Software Operation Manual (CD media)
- Ultra320 SCSI Cable x1
- RS232 cable x1
- Ultra320 SCSI Active Terminator x1
- Power Cord x 2
- FAN x 1
- HDD tray x 1
- Mounting screws (bag) ×1

Fibre to ATA RAID system

- RAID System x1
- RAID system Hardware Installation Guide (CD media)
- RAID system Software Operation Manual (CD media)
- RS232 cable x1
- Power Cord x 2
- FAN x 1
- HDD tray x 1
- Mounting screws (bag) ×1



Note

To avoid the unmatched cable between the Fibre HBA in the Host and Fibre-SATA RAID SYSTEM, Fibre-SATA RAID system doesn't include the Fibre interface with the standard configuration. There are many different kinds of Fibre connectors on varied of Fibre HBAs.

What else you need

- Hard disk drives (different RAID levels requires different numbers of HDDs). Refer to Software Operation manual for more detail information.
- Host computer with SCSI interface (**SCSI-SATAII RAID SYSTEM**)
- Host computer with Fibre interface (**Fibre-SATAII RAID SYSTEM**)
- Static grounding strap or electrostatic discharge (ESD) safe work area
- Dedicated terminal or PC with third party communication software that supports ANSI terminal emulation (required for viewing Monitor Utility)



Note

The hard drives in a RAID system should match in size and speed. All drives in any array should be identical models with the same firmware versions. RAID system can use any size drive, however the smallest drive will determine the size of the array.



Note

There's no set formula to determine how much cache memory to use, but as a general rule, a workstation, with mostly very large files, such as for audio or video editing and playback, graphics or CAD files, can benefit from a large cache. File servers, with multiple random access of varying file size, generally have little or no performance improvement with additional cache.



Note

RAID system do not require the installation of different drivers for use with different operating systems. RAID system is independent and transparent to the host operating system.

Identifying Parts Of The RAID system

The illustrations below identify the various parts of the RAID SYSTEM. Get yourself to familiar with these terms as it will help you when you read further in the following sections :

Front View

YI-16SAEU4/YI-16SAEF2/YI-16SA2F2

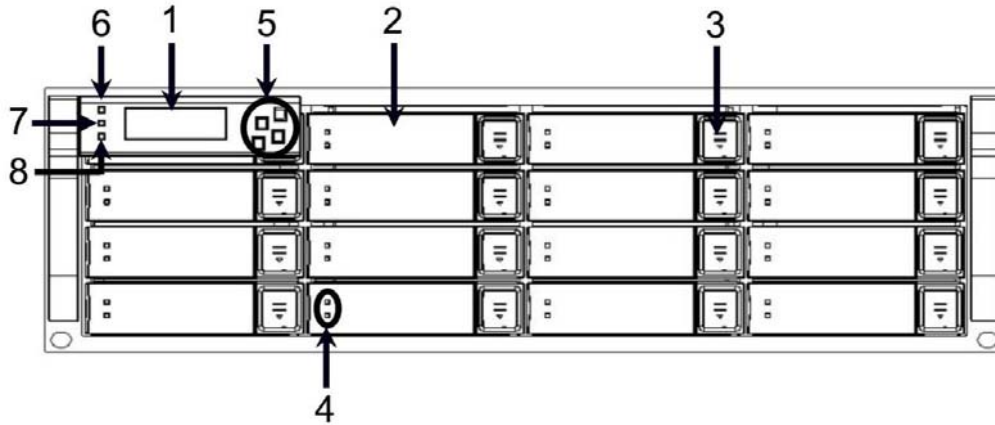

YI-12SAEU4/YI-12SAEF2

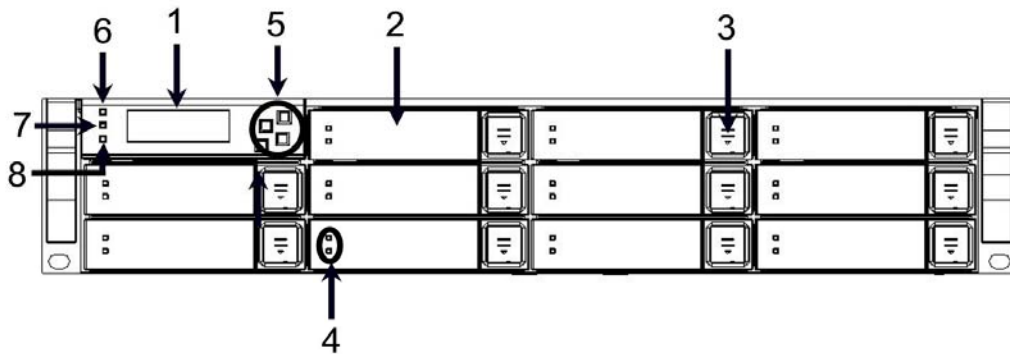

YI-08SAEU4/YI-08SAEF2

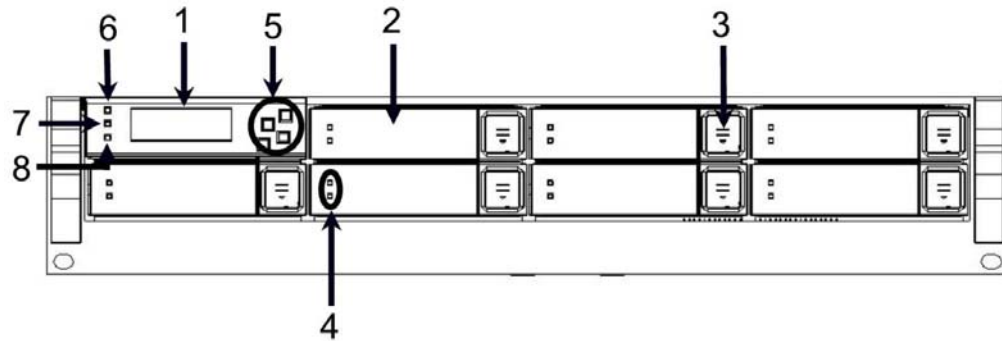

1. LCD Display Panel.

The front panel LCD continuously displays the status of the RAID SYSTEM. The following is an example of the RAID SYSTEM

2. Cartridge Handle

3. Lock & Release-Button



4. HDD status LED Indicator

LED	Colors	Indicate
	Blue or Green	HDD On Line
	Blue + Blink or Amber	HDD Access
?	Red	HDD Error

Hardware Installation Guide

5. Function keys. (ENT , ESC, Scroll up , Scroll Down)

Keys	Descriptions
Up Arrow	To scroll upward through the menu items
Down Arrow	To scroll downward through the menu items
(ENT) Enter	To confirm a selected item
(ESC) ESC	To exit a sub-menu and return to previous menu.

6.  Power On Indicator (Blue or Green).
7.  Power Fail Indicator (Red)
8.  Host System Access Indicator (Blue + blink or Yellow).

Rear View YI-16SAEU4

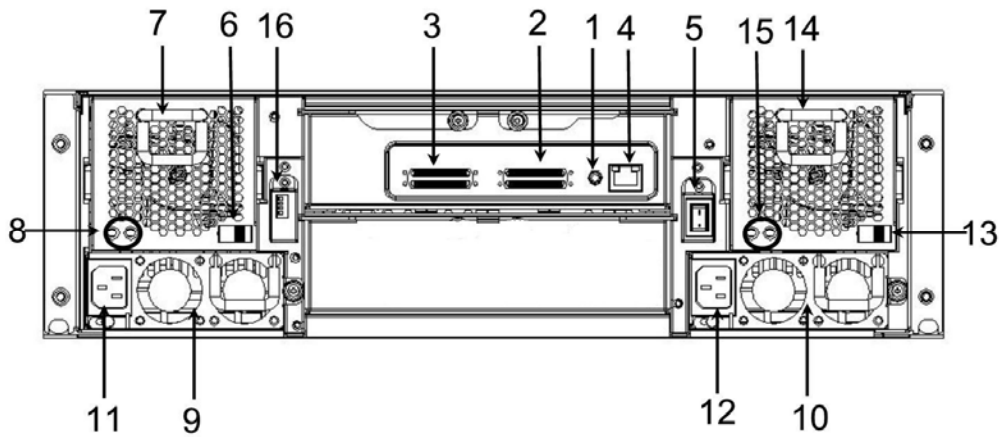

YI-16SAEF2

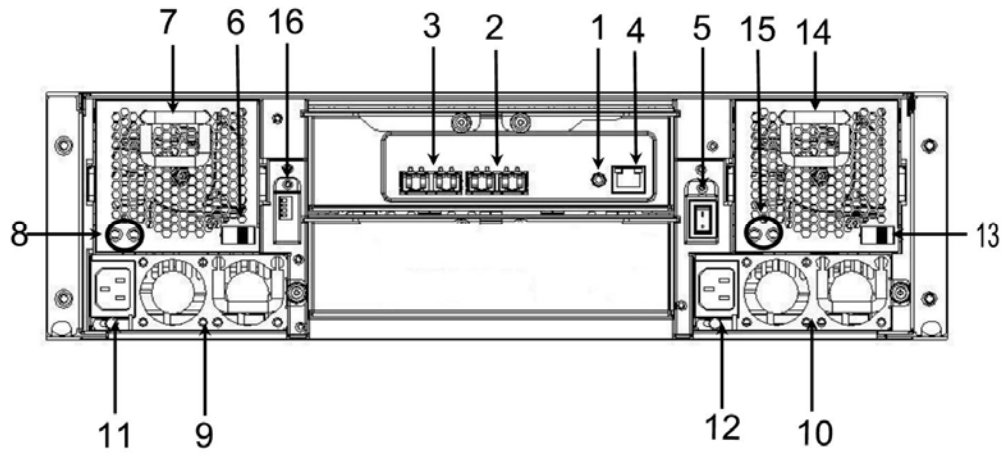

YI-12SAEU4/YI-08SAEU4

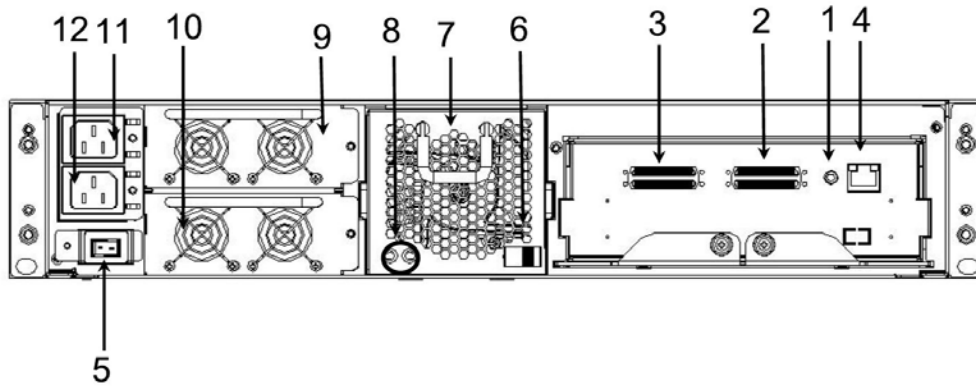

YI-12SAEF2/YI-08SAEF2

Hardware Installation Guide

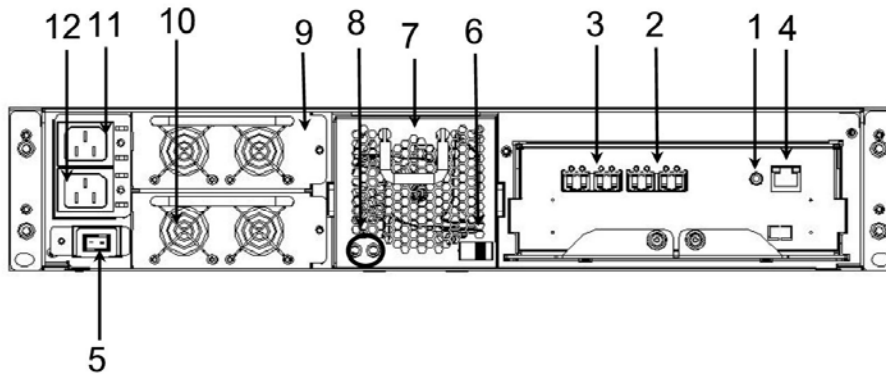

1. Terminal

SCSI-ATA RAID SYSTEM:

2. SCSI Channel 0

3. SCSI Channel 1

Fibre-ATA RAID SYSTEM:

2. FC Channel 0

3. FC Channel 1

4. LAN port

5. Power Switch

6. FAN Module /FAN Module 1 latch

7. FAN Module /FAN Module 1

8. FAN failure indicator (Rear / Front)

9. Power Module 1

10. Power Module 2

11. AC inlet 1 & Ltch

12.AC inlet 2 & Latch

13. FAN Module 2 latch

14. FAN Module 2

15. FAN failure indicator (Rear / Front)

Space Requirement

When selecting a location for your system, be sure to allow an adequate space. The system has vents around it which will require a minimum of 3 inches of unobstructed space for airflow. Openings in the equipment should be blocked, or there may be an issue of reliability problems with your system. A system product should never be placed around a radiator or heat register.

System Connection

Connect all cables and power cord as shown below:

Cable	RAID system	Device	Purpose
RS-232 cable	RS-232 Port	ANSI Terminal or a PC with Hyper terminal	Terminal Utility for configuration and Monitoring
SCSI Cable / Fibre cable	Primary SCSI/FC-AL or Secondary SCSI/FC-AL	SCSI/FC-AL HBA of Host Computer	Host Interface
Power Cord	Power Inlet	A/C Power Outlet	A/C power input
RS-232 cable	Modem Port	Modem	Event notification via Fax and page



Note

Make sure that all the devices are powered off before connecting or removing cables to prevent power spikes which can damage technical components.

Install hard disks

The RAID SYSTEM includes 8/12/16 (depending on your models) removable disk cartridges.

The following sections describe how to install disks into RAID SYSTEM subsystems.

Remove Cartridges

We designed the lock/unlock mechanism on a same button and called *EzSecurLock* . No need a key but with security .

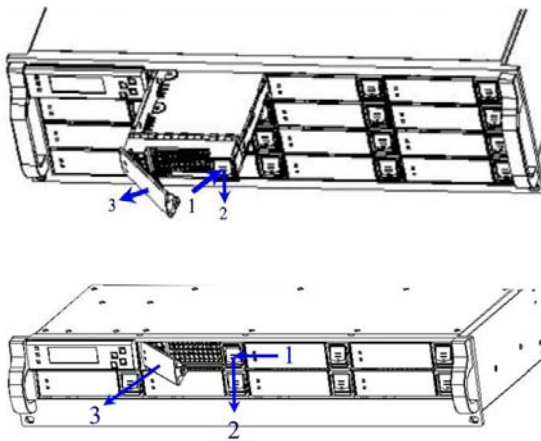

How to remove Cartridges?

- 1: Push the button inward
- 2: While holding in the button, then slide down
- 3: The HDD door will be opened automatically.

Install HDDs.

1) Put HDD into the Cartridge.

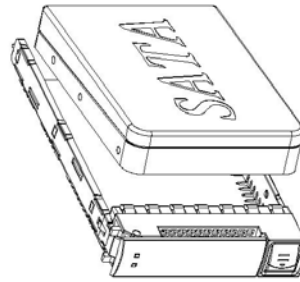

2) Align 4 screws holes on both HDD & Cartridge.

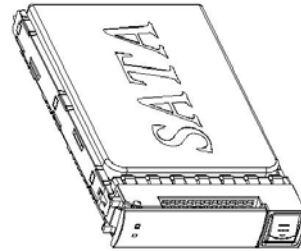

3) Fasten all 4 screws to mount HDD in the cartridge and make sure the HDD is properly tightened.

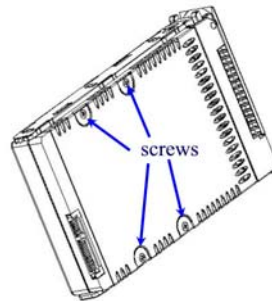

Install Cartridges

Reversed the procedures of “Remove cartridges” to install cartridges back to RAID system .

Chapter 2

Hardware Installation

This chapter presents:

- ⇒ **Instructions on replacing components**
- ⇒ **Instructions on replacing the hot swappable components**
- ⇒ **Instructions on how to install and upgrade DRAM**

Replace the Controller



Caution

Read the replacing notices earlier in this chapter before proceeding with replacement.

This section provides instructions for the removal and installation of the RAID controller components indicated in the figure below. This section is for the reference of engineers. End users should not need to replace or remove components.

Removing the controller from YI-08/YI-12/YI-16 series
YI-16SA

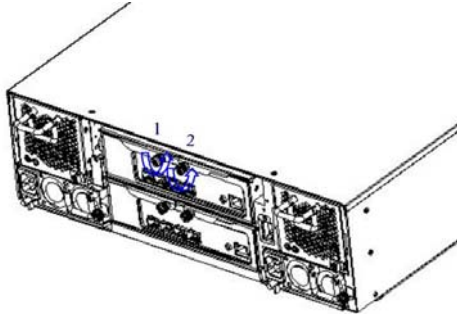

- 1: Disconnect the host cables.
- 2: Turn anti-clock wise to release the thumb screw.

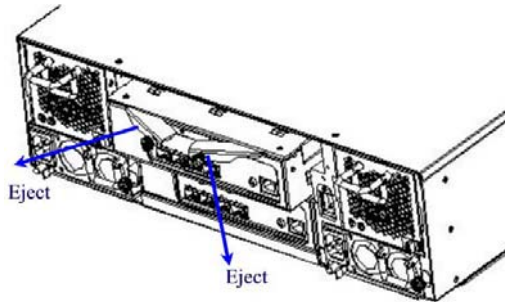

- 3: Use the eject kit to remove controller board.

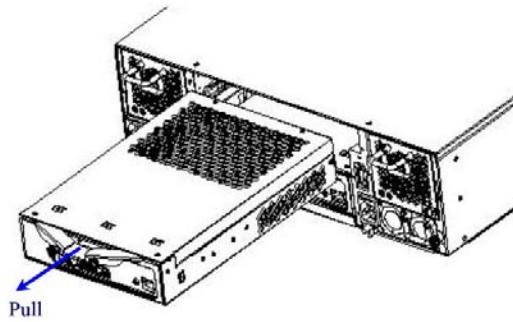

- 4: Slide it back and lifting off

Installing the controller into YI-16SA

Reverse the procedures as above to install the controller into YI-16SA.

Hardware Installation Guide

YI-08SAE/YI-12SAE

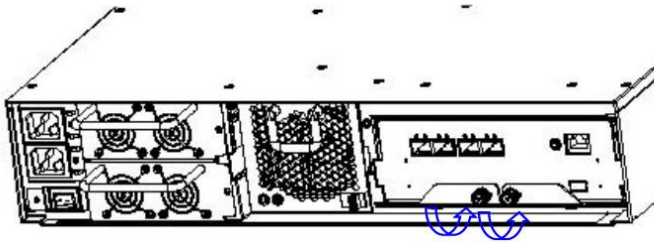

- 1: Disconnect the host cables.
- 2: Turn anti-clock wise to release the thumb screw.

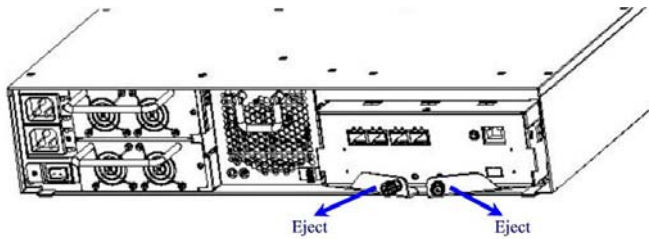

- 3: Use the eject kit to remove controller board.

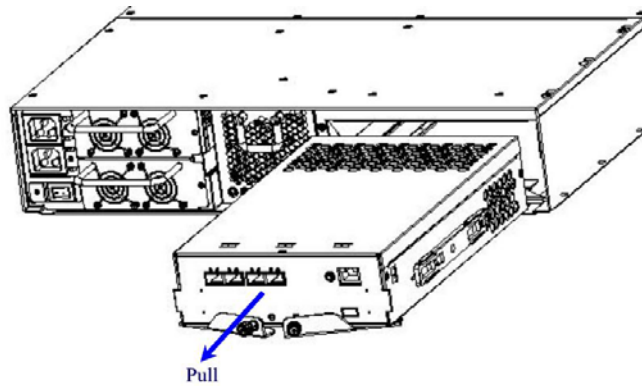

- 4: Slide it back and lifting off

Installing the controller into YI-08SA/YI-12SA

Reverse the procedures as above to install the controller into YI-08SA/YI-12SA.

Replacing / Upgrading DDR SDRAM



Caution

Read the pre-installation notices earlier in this chapter before proceeding with installation.

RAID SYSTEM is normally supplied with 256MB DDR SDRAM installed.



Note

There's no set formula to determine how much cache memory to use, but as a general rule, a workstation, with mostly very large files, such as for audio or video editing and playback, graphics or CAD files, can benefit from a large cache. File servers, with multiple random access of varying file size, generally have little or no performance improvement with additional cache.

Memory serves as the data buffer to increase the CPU utilization rate and minimize the overhead of data accessing , thus, improves the overall performance. YI-08SA/12SA/16SA supports up to 2GB DDR SDRAM at 333Mhz with or without ECC & register type memories .

The DDR memory socket is used 184-pin DIMM socket . Use 90 degree of memory slot type

DDR SDRAM DIMM specifications:

Minimum	Recommended
<ul style="list-style-type: none"> ■ 184-pin DDR SDRAM DIMM module (DDR-333). 	<ul style="list-style-type: none"> ■ DDR333
<ul style="list-style-type: none"> ■ DDR SDRAM DIMM, with or without ECC & Register type 	<ul style="list-style-type: none"> ■ With ECC, for security
<ul style="list-style-type: none"> ■ Minimum of one DDR DIMM with 256 MB. The memory card socket can support , 256M, 512 MB ,1GB or 2GB of memory. 	<ul style="list-style-type: none"> ■ Minimum of 256 MB. More memory (up to 2GB) equals better performance: the size of the memory module defines the cache writing space available to the RAID SYSTEM.

Installing memory module

To install a DDR SDRAM ensure the system is power off and disconnected. Then:

- 1: Removing the controller module from Raid system.
- 2: Open the cover of controller module .
3. Insert a memory module into the memory socket .
4. Close the cover of controller module .

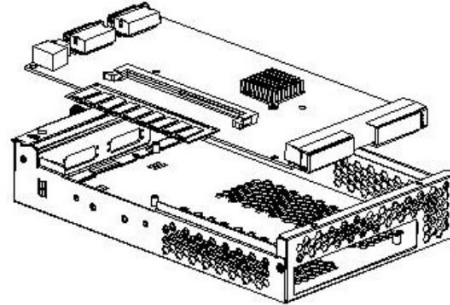

Caution

Before starting any kind of hardware installation, please ensure that all power switches have been turned off and all power cords disconnected to prevent personal injury and damage to the hardware



Caution

Use screws provided with RAID system only. Longer or shorter screws may cause electric shorting or un-proper installed.



Caution

Static electricity can damage electronic components. To guard against such damage:

Work in a static-free environment

Wear a grounded anti-static wrist strap

Store uninstalled components in anti-static bags

Handle PCBs by their edges and avoid touching chips and connectors.

Hot Swapping to replace the Fan Module

This section provides instructions for the removal and installation of the Fan Module indicated in the figure below.

YI-16SAEF2/YI-16SAEU4

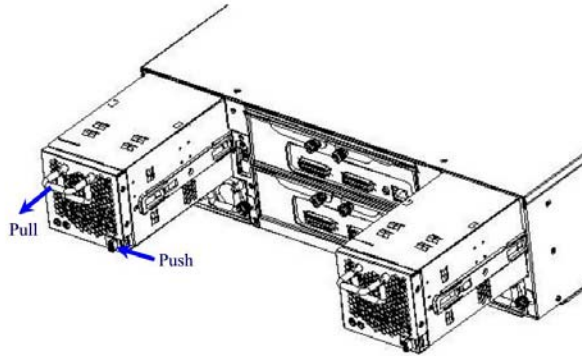

Removing the Fan Module from RAID system

Remove the Fan modules by pushing the latch to release the lock of module then slide it back and lifting off.

YI-08SAEF2/YI-08SAEU4/YI-12SAEF2

YI-12SAEU4

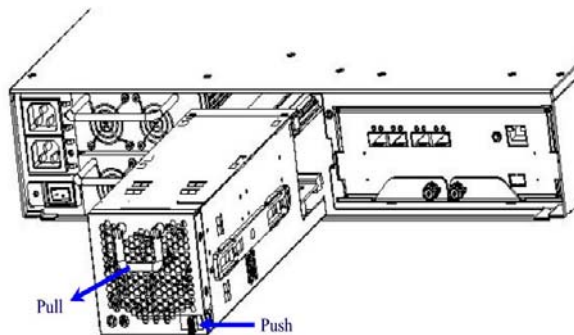

Installing the Fan module into RAID system :

Insert a Fan module into system , the latch will lock the Fan module automatically.

Replacing Fan in a Fan Module:

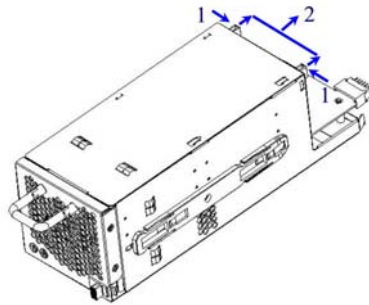

Step 1: Push the two latches at same time.

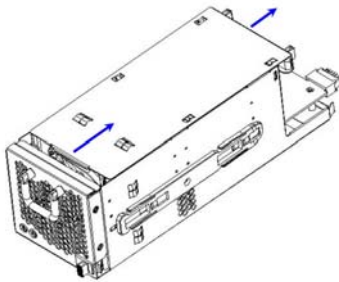

Step 2: While holding the two latches , then slide the cover to blue arrow direction.

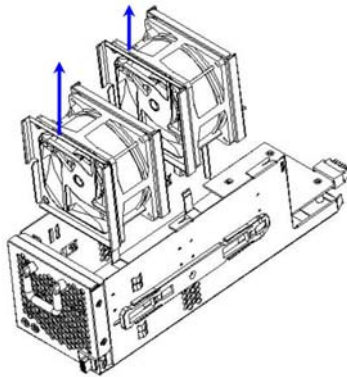

Step 3: Remove the cover of Fan module and lift the Fans .

Hot Swapping to replace the Power Module

This section provides instructions for the removal and installation of the Power Module indicated in the figure below.

Removing the Power Module from RAID system YI-16SA :

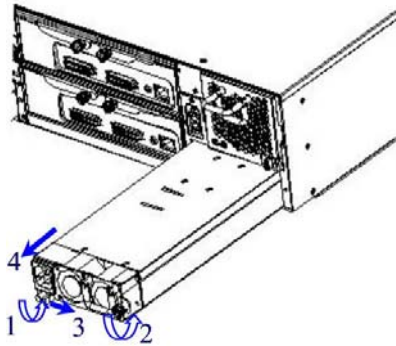

Step1&2: Unscrew the fastener.

Step3:Release the latch and hold it at unlock-position.

Step4:Slide it back and lifting off.

Removing the Power Module from RAID system YI-08SAE/YI-12SAE :

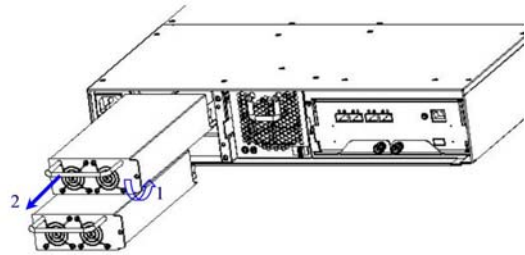

Step1: Unscrew the fastener

Step 2: Slide it back and lifting off.

Installing the Power module into RAID system :

Insert a Power module then fasten the screw.



Note

The Power indicator will turn bright “Green” to indicate it has powered on

Turning on for the first time

When cabling is completed, RAID SYSTEM can be turned on. This should be done in the following order:

1. First turn on the power switch of RAID SYSTEM.
2. Then power on and boot the host computer(s)

When RAID SYSTEM is running, you are ready to configure one or more RAID arrays. You have the following options:

1. Turn to Chapter 2 of “Software Operation Manual” to perform a quick setup of a single RAID array using the control panel.
2. Turn to Chapter 3 of “Software Operation Manual” to access the Monitor Utility. Once the Monitor Utility is accessed, you can perform a Quick Setup (Chapter 2) or complete configuration (Chapter 4) with either the control panel or Monitor Utility.
3. Turn to Chapter 4 of “Software Operation Manual” to perform a full configuration using the control panel.

Turning off

When turning off RAID SYSTEM, users are advised to first shut down the server, then power off RAID SYSTEM.

Restarting

When restarting RAID SYSTEM, users are advised to first restart the server, then power on RAID SYSTEM.

Appendix A

Trouble Shooting

Problems setting up

Newly installed memory fails during Self-Test or is not detected.

Possible Cause: *The Memory DDR DIMM module may not be properly seated or may not be supported by RAID SYSTEM.*

Fix: *Re-sit the memory module in the socket and retry. If it continues to fail try moving it to the other memory socket. Make sure the correct memory type is being installed. RAID SYSTEM supports 184-pin DDR DIMM SDRAM.*

Unable to access RAID SYSTEM after the operating system boots up.

Possible Cause: *RAID SYSTEM is not configured.*

Fix: *Make sure RAID SYSTEM is configured for a RAID level. If no RAID level is configured the operating system will not detect RAID SYSTEM as a disk drive.*

I try to set up an array using Quick Setup but fail. Why?

Possible Cause: *If the error message Array1 Exists! appears, an array has already been configured. Quick Setup can only be used to new RAID arrays.*

Fix: *Reconfigure the array from the RAID params submenu*

Problems during operation

The front panel LCD displays alternating “Zz” characters.

Possible Cause: *These characters are displayed when the cache is full with write request data that have not been processed. Requests from the host are halted to flush the data in the cache.*

Fix: *None needed.*

The front panel LCD displays alternating “Ww” characters.

Possible Cause: *These characters are displayed to indicate that write requests in the cache are being processed. When these characters are displayed, RAID SYSTEM will halt requests from the host (see above).*

Fix: *Make sure the Write Buffer option of the RAID Params menu is enabled. In addition, more cache memory may be required. By increasing the cache memory, the write buffer space*

Hardware Installation Guide

increases and will be able to handle the higher write requests.

LCD display shows OWOOOS

Possible Cause: “W” means “warning” - there are many bad sectors on your HDD.

Fix: Change hard drives.

Invalid NVRAM message appears

Possible Cause: NVRAM error or malfunction.

Fix: Save settings and restart the controller. If the problem persists, contact your vendor.

Data loss for Windows 2000 during system shutdown

Possible Cause: RAID controller is in a process of a built-in host and some data is still in cache buffer during system shutdown.

Fix 1: Set Cache Off

Fix 2: To shutdown, select Restart system and wait for 30 seconds, then power off the system.

Fix 3: Shutdown host OS after shutting down controller.

Remote terminal problems

Unable to access Configuration Mode using the remote terminal interface.

Possible Cause 1: The terminal communication settings do not match the settings of the RAID SYSTEM RS-232 interface.

Fix: The default settings for the RS-232 port are 19,200 Baud rate, 8 Data bits, 1 Stop bit, No Parity, and XON/XOFF Flow control. Make sure the terminal is configured for these settings. If the settings were changed in Configuration Mode, verify the settings of the RAID SYSTEM in the RS-232 Params, Terminal option and change the terminal settings accordingly.

Possible Cause 2: Incompatible RS232 cable.

Fix: Cross pins on the RS-232 cable as shown below (or use a null modem cable). The only pins used are 2 3 & 5.

```
1 2 3 4 5 6 7 8 9
  X  I
1 2 3 4 5 6 7 8 9
```

Alert message problems

I am unable to send a Page or FAX using the modem port.

Possible Cause 1: *The Page and Fax options are not enabled.*

Fix: *Go to the Configuration Mode and enable Page and FAX notification via the System Params menu option.*

Possible Cause 2: *The default modem initialization string is not compatible with your modem.*

Fix: *Change the modem initialization string in the System Params option. Refer to your modem manual for its initialization string.*

The following modem models require their own initialization strings.

Modem Model	Initialization String	Baud Rate	FAX Class
Motorola ModemSURFR V.34 28.8	AT&D\Q1E	Up to 38400	1 & 2
Multitech Multimodem 2834ZDX	AT&D0&E5E0	Up to 38400	2 only
Hayes Accura 288 V.34+FAX	AT&D0&K4E0	38400 only	1 & 2
Practical Peripherals PM144MT II	AT&K4	Up to 38400	2 only
GVC F-1128V/T2	AT&D0&B1&H2	38400 only	1 & 2
US Robotics Sportster 28800	AT&H2&I1&R1&B1	38400 only	1 only

SCSI problems

RAID SYSTEM is not properly identified by the SCSI adapter during initialization of the computer system.

Possible Cause: *The SCSI ID set for the RAID SYSTEM is being used by another SCSI device*

attached to the same SCSI card.

Fix: *Select the Set SCSI ID option from the SCSI Params menu and specify a different SCSI ID. Most SCSI host adapters provide an onboard ROM BIOS, or software utility, that displays the devices attached and their SCSI IDs. Disconnect RAID SYSTEM from the SCSI host adapter card and during the system boot, or by running the utility, note the SCSI IDs already in use.*

The RAID SYSTEM is identified as all SCSI IDs.

Possible Cause: *The SCSI ID set for RAID SYSTEM is identical to the reserved SCSI ID used by the SCSI card in your system.*

Fix: *Select the Set SCSI ID option from the SCSI Params menu and specify a different SCSI ID. Most SCSI host adapter cards reserve SCSI ID 7 for the card ID.*

The SCSI host adapter card does not detect RAID SYSTEM.

Possible Cause: *Incorrect termination in a daisy chain configuration or a loose cable in a stand-alone configuration.*

Fix: *In a daisy chain configuration, verify that only the SCSI host adapter and the last SCSI device is terminated. To change termination settings of RAID SYSTEM, use the SCSI Params menu SCSI Termination option to enable or disable termination.*

Appendix B

Connectors

SCSI Connector

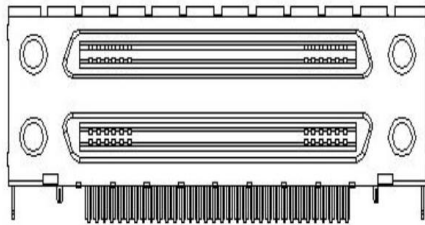

Pin#	Signal Name	Pin#	Signal Name
1	SCSI_AC_DAT<12>+	35	SCSI_AC_DAT<12>-
2	SCSI_AC_DAT<13>+	36	SCSI_AC_DAT<13>-
3	SCSI_AC_DAT<14>+	37	SCSI_AC_DAT<14>-
4	SCSI_AC_DAT<15>+	38	SCSI_AC_DAT<15>-
5	SCSI_AC_PAR<1>+	39	SCSI_AC_PAR<1>-
7	SCSI_AC_DAT<1>+	41	SCSI_AC_DAT<1>-
8	SCSI_AC_DAT<2>+	42	SCSI_AC_DAT<2>-
9	SCSI_AC_DAT<3>+	43	SCSI_AC_DAT<3>-
10	SCSI_AC_DAT<4>+	44	SCSI_AC_DAT<4>-
11	SCSI_AC_DAT<5>+	45	SCSI_AC_DAT<5>-
12	SCSI_AC_DAT<6>+	46	SCSI_AC_DAT<6>-
13	SCSI_AC_DAT<7>+	47	SCSI_AC_DAT<7>-
14	SCSI_AC_PAR<0>+	48	SCSI_AC_PAR<0>-
15	GND	49	GND
16	GND	50	GND
17	TERMPWRA	51	TERMPWRA
18	TERMPWRA	52	TERMPWRA
19	GND	53	GND
20	GND	54	GND
21	SCSI_AC_ATN_L+	55	SCSI_AC_ATN_L-
22	GND	56	GND
23	SCSI_AC_BSY_L+	57	SCSI_AC_BSY_L-
24	SCSI_AC_ACK_L+	58	SCSI_AC_ACK_L-
25	SCSI_AC_RST_L+	59	SCSI_AC_RST_L-
26	SCSI_AC_MSG_L+	60	SCSI_AC_MSG_L-
27	SCSI_AC_SEL_L+	61	SCSI_AC_SEL_L-
28	SCSI_AC_CD_L+	62	SCSI_AC_CD_L-
29	SCSI_AC_REQ_L+	63	SCSI_AC_REQ_L-
30	SCSI_AC_IO_L+	64	SCSI_AC_IO_L-
31	SCSI_AC_DAT<0>+	65	SCSI_AC_DAT<0>-
32	SCSI_AC_DAT<9>+	66	SCSI_AC_DAT<9>-
33	SCSI_AC_DAT<10>+	67	SCSI_AC_DAT<10>-
34	SCSI_AC_DAT<11>+	68	SCSI_AC_DAT<11>-

Modem Male Connector

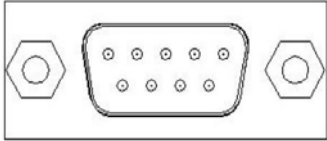

Pin#	Signal	Pin#	Signal
1	DCD	6	DSR
2	RXD	7	RTS
4	DTR	9	TXC
5	GND		

Terminal port (Audio to RS-232)

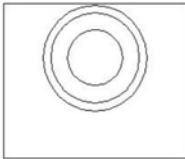

Network Management Port

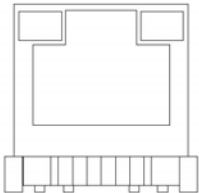

SFP FC connector

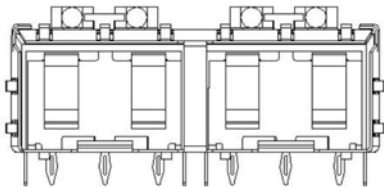

Appendix C

Specifications

YI-16SAEU4/YI-16SAEF2

Model	YI-16SAEU4	YI-16SAEF2
	U4	FC
RAID Engine	Intel i80331 64bit RISC CPU	
RAID Levels	0, 1, 0+1, 3, 5 ,30,50 ,6 ,6 + , NRAID & JBOD	
Cache Support (Write back)	Up to 2GBytes with ECC/Without ECC 184pins DDR SDRAM Memory	
System Type	Rack mountable	
Host Interface	Dual Ultra U320 SCSI Channels	Dual loops 2Gb Fibre Channels, Standard SFP connectors
Host Transfer Rate	320 MB / Sec per channel	2Gb/ Sec per loop
Disk Interface	SATA 3.0 Gbps	
Disk Channel	Sixteen SATA 3.0 Gb Disk Channels	
LCD Display	2 Lines by 16 Characters	
Hot Swap and redundant	Yes (Power Supply, Drive and Fan).	
Hot Spare	Yes (Drive).	
Battery Back-Up Module	Optional , Support up to 72hrs battery back-up time (N.A.)	
Array Management Support	Yes.	
Automatic Bad-Sector & Error Recovery	Yes.	
Automatic Drive Rebuilds	Yes. Automatic Data rebuilds.	
Audible Alarm, Pager and Fax Notification	Yes. The Pager and Fax Notification have to connect a external modem.	
Remote Terminal Configuration	Yes. Through Network port .	
Operating Systems	O/S Independent and Transparent	
Power Supply	460+460 watts Redundancy high quality power system, two 460 watts module with PFC function. Load sharing type and cable-less design with Redundancy Dual Power inlet	
Electrical	AC Voltage 100-240 VAC Ac Frequency 47-63Hz	
Temperature	Operating Temperature : 5 to 35 degree C. Non Operating Temperature : -40 to 60 degree C.	
Relative Humidity	20% to 80% non-condensing	
Dimensions	447mm(W)*496mm(D)*3U(H)	
Weight	28KG	

Hardware Installation Guide

YI-08SAEU4/YI-08SAEF2/YI-12SAEU4/YI-12SAEF2

Model	YI-12SAEU4	YI-12SAEF2	YI-08SAEU4	YI-08SAEF2
	U4	FC	U4	FC
RAID Engine	Intel i80331 64bit RISC CPU			
RAID Levels	0, 1, 0+1, 3, 5 ,30,50 ,6 ,6 + , NRAID & JBOD			
Cache Support (Write back)	Up to 2GBytes with ECC/Without ECC 184pins DDR SDRAM Memory			
System Type	Rack mountable			
Host Interface	Dual Ultra 320 SCSI Channels	Dual loops 2Gb Fibre Channels, Standard SFP connectors	Dual Ultra 320 SCSI Channels	Dual loops 2Gb Fibre Channels, Standard SFP connectors
Host Transfer Rate	320MB / Sec per channel	2Gb / Sec per loop	320MB / Sec per channel	2Gb/ Sec per loop
Disk Interface	SATA 3.0 Gbps			
Disk Channel	Twelve of SATAII Disk Channel		Eight of SATAII Disk Channel	
LCD Display	2 Lines by 16 Characters			
Hot Swap and redundant	Yes (Power Supply, Drive and Fan).			
Hot Spare	Yes (Drive).			
Battery Back-Up Module	Optional , Support up to 72hrs battery back-up time (N.A.)			
Array Management Support	Yes.			
Automatic Bad-Sector & Error Recovery	Yes.			
Automatic Drive Rebuilds	Yes. Automatic Data rebuilds.			
Audible Alarm, Pager and Fax Notification	Yes. The Pager and Fax Notification have to connect a external modem.			
Remote Terminal Configuration	Yes. Through network port.			
Operating Systems	O/S Independent and Transparent			
Power Supply	PA-16: 375+375 watts Redundancy high quality power system, three 375 watts module with PFC function. Load sharing type and cableless design with Redundancy Dual Power inlet			
Electrical	AC Voltage 100-240 VAC Ac Frequency 47-63Hz			
Temperature	Operating Temperature : 5 to 35 degree C. Non Operating Temperature : -40 to 60 degree C.			
Relative Humidity	20% to 80% non-condensing			
Dimensions	447mm(W)*515mm(D)*3U(H)			
Weight	28KG			



Note

**Specification subject to change without notice, all trademarks or registered trademarks are properties of their respective owners.*